

SIGMA Thermo Tank



SMART TESTING. PROVEN EXCELLENCE

About SIGMA Thermo Tank

SCITEQ



“The compact design of the SIGMA thermo tank is a cost-effective solution, that reduces footprint to a minimum while at the same time minimizing the energy consumption.

The compact footprint makes the solution ideal for smaller laboratory layouts”

About SIGMA Thermo Tank

SCITEQ

Standards

The SIGMA Thermo tank enables you to test according to below standards:

- ISO 9967
- ASTM D1598
- ASTM D1599

The Thermo tanks may very well enable you to test according to other standards beside the ones listed above. Please refer to technical specifications in the back of this brochure or contact SCITEQ A/S for more information.

Highlights

The SIGMA Thermo Tank features:

- High-end industrial design feature
- Uniform constant temperature
- Accurate PID temperature control
- Temperature setting +/- 0,1 °
- Low energy consumption
- Only supply of water and power to operate.
- Automatic water level control
- High quality parts
- 270 ° accessibility to tank
- Easy access - service & maintenance
- Long lifetime construction
- Low noise level
- Full 3D documentation and easy identification of spare parts





SIGMA Pressure test system

The SIGMA pressure test system consists of Pressure test cabinets configured with 5 to 50 pressure test stations for hydrostatic pressure testing of pipes and fittings at 10-200 bar standard. High pressure testing of up to 1500 bar for reinforced plastic pipes is the latest development to the SIGMA family. The SIGMA thermo tanks are used for conditioning of test samples and as test chamber when running the static, step and burst test.

The web based SIGMA software offers an intuitive interface featuring quick-to-setup recipes as well as optimized real time monitoring & logging enabling comprehensive analysis options of tests.

About SIGMA Thermo Tank

SCITEQ

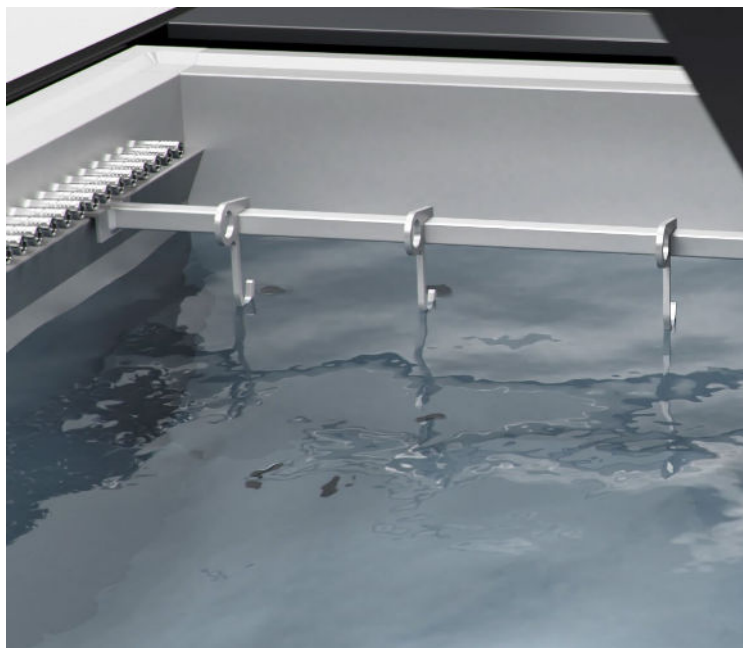

Scope

The SIGMA Thermo Tanks are primarily used for immersing pipe samples in water at a accurately controlled temperature, during hydrostatic pressure test, but also for conditioning of any type of sample that requires controlled temperature immersion.

The Thermo tanks are suitable for testing according to ISO 1167, ASTM D1598 and ASTM D1599



Range

The SIGMA Thermo Tank is available in two standard dimensions suitable for countless specimen configurations. The standard product program covers a range of internal dimension from 1100x1100x1100 mm to 2400x1100x1100 mm (LxWxH), meaning a volume range of 1.25 – 2,75 m³ water. The solution includes configurable access points and a hanger system to suit individual needs.

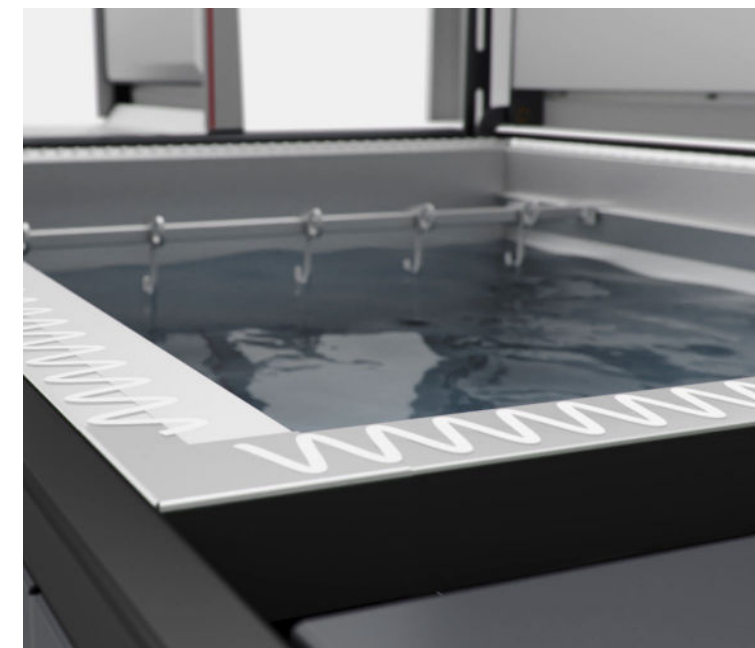

Construction

The SIGMA Thermo Tank is designed with focus on energy efficient operation, intuitiv & ergonomical use and cost efficient construction. The tank consists of an outer heavy duty frame in painted steel with easy removeable cover plates. An inner tank in stainless steel (Aisi 316 and others on request). The compact layer of Rockwool isolation reduces energyloss and eliminates the risk of hot outer surfaces.

Features SIGMA Thermo Tank

SCITEQ



Drip Edge

The Thermo Tanks are equipped with an inner tank produced with laser cut, bended, stainless steel plate. The unique design of the lid ensures condensation is lead into the tank when opening the lid.

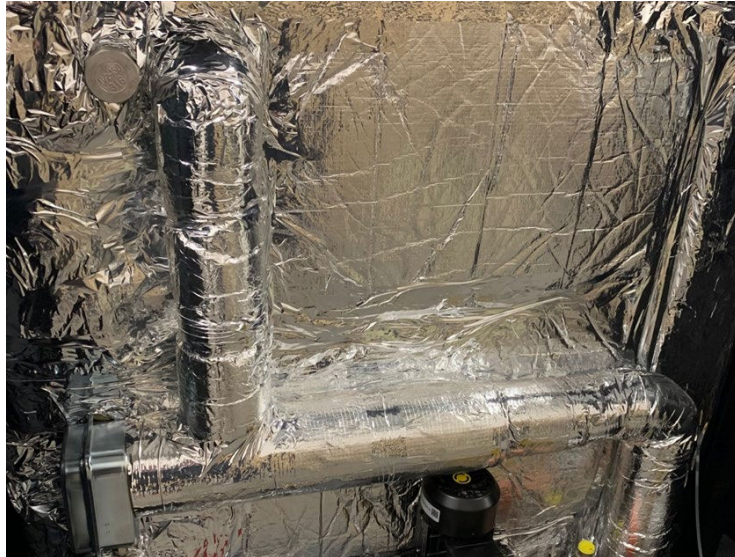

Low energy consumption

The Thermo tanks are designed with a direct aim of reducing the energy consumption. Therefore inner tank is fully isolated thick mineral wool to reduce heat loss and risk of hot surfaces. Along with the use of high end efficient, Grundfoss circulation pump, JEVI electric heating elements and accurate PID Controlled temperature regulator makes sure energy consumption is kept at a very low level under operation.

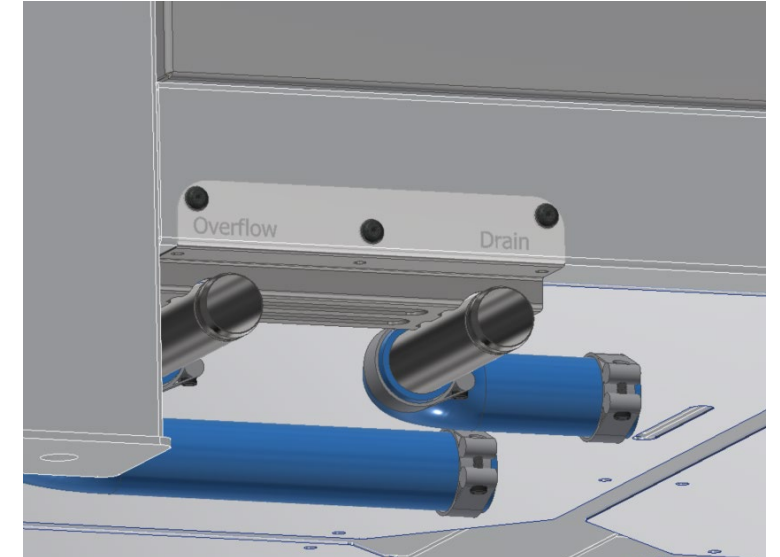

Flex drain connection

The flexible connection interface enables easy configuration of the drain and overflow drain. The drain and overflow can be placed according to customer layout on site. SCITEQ supplies a flange including drain and overflow drain valve.

Features SIGMA Thermo Tank

SCITEQ

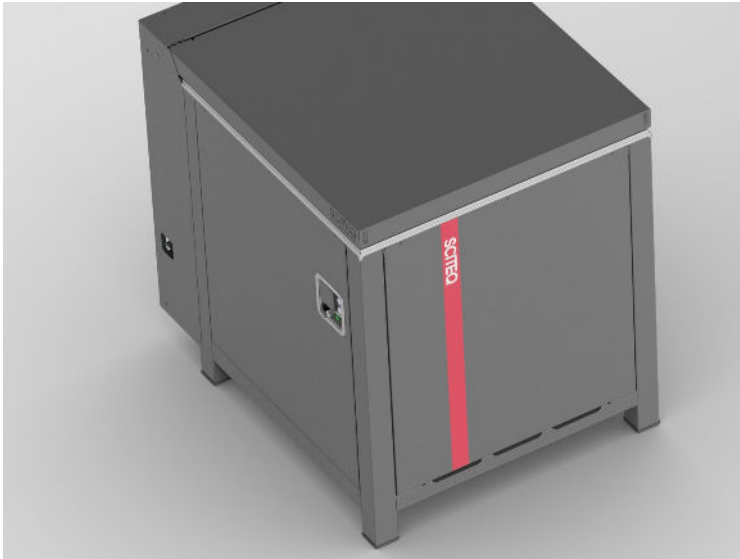

Control

The tank has a build-in control cabinet and integrated control panel with easy access from side/front of the tank.

When activated the interlock function prevents opening the tank lid. This safety feature also disables interfering during ongoing tests.



Prepared for chiller

The tank is prepared for easy connection of a chiller, which can be supplied by SCITEQ or any other chiller of customer choice. The chiller function is for maintaining a certain temperature (not for cooling down tank water). Please refer to technical specification table.



Connection points

SCITEQ is using TEMA 2510 couplings for quick and easy connection to the specimens. SCITEQ supplies hanging bars and hooks, for easy fixating of the specimens inside the tank. Other types of couplings, hooks, hoses etc. can be supplied, please see section Accessories. SCITEQ supplies hoses to connect pressure stations and tank as well as for use inside the tank. Hoses can be supplied in different lengths according to need.

Dimensions SIGMA Thermo Tank

SCITEQ

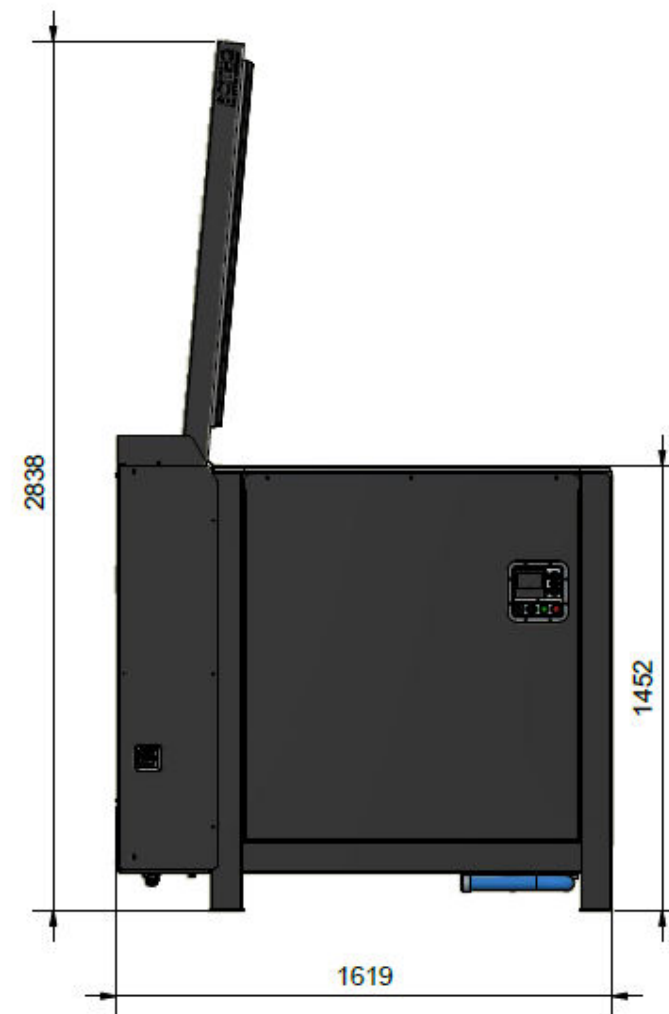
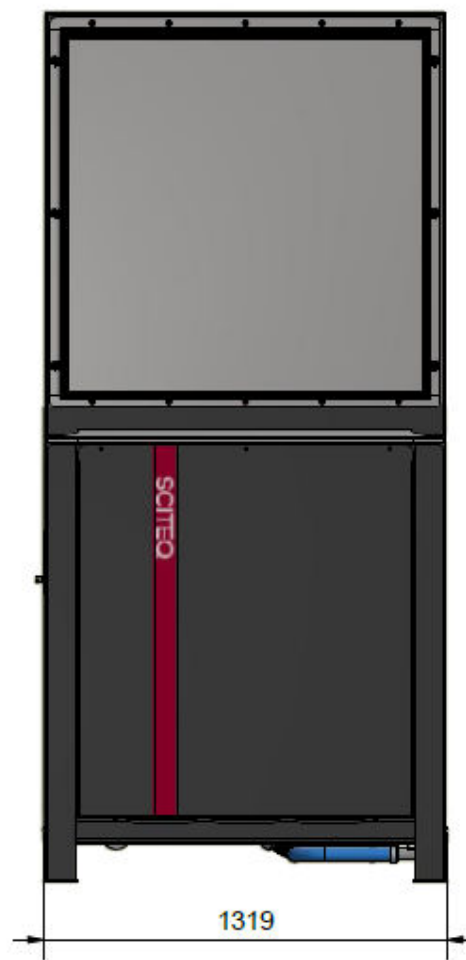

Dimensions SIGMA Thermo Tank

SCITEQ

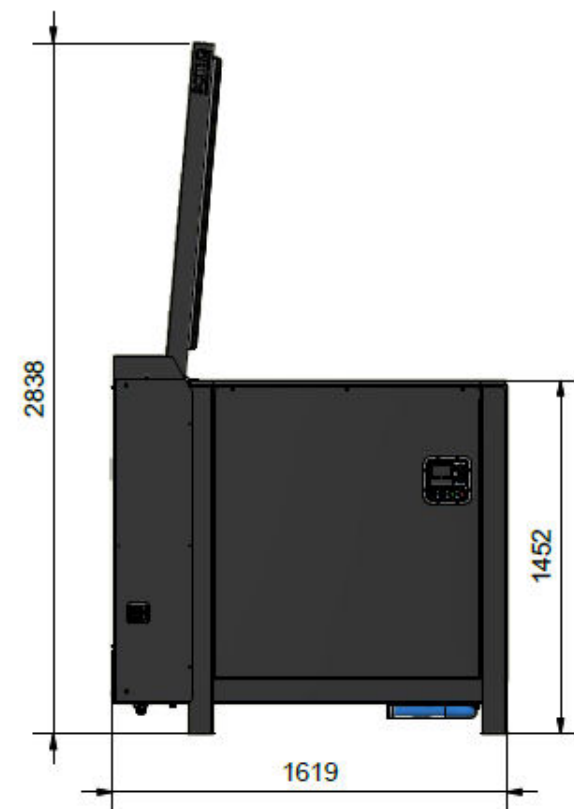
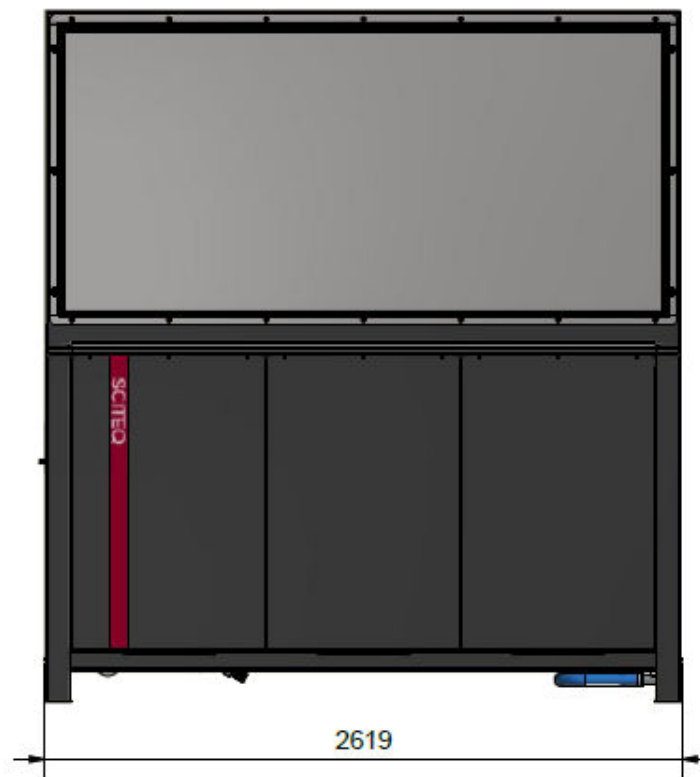
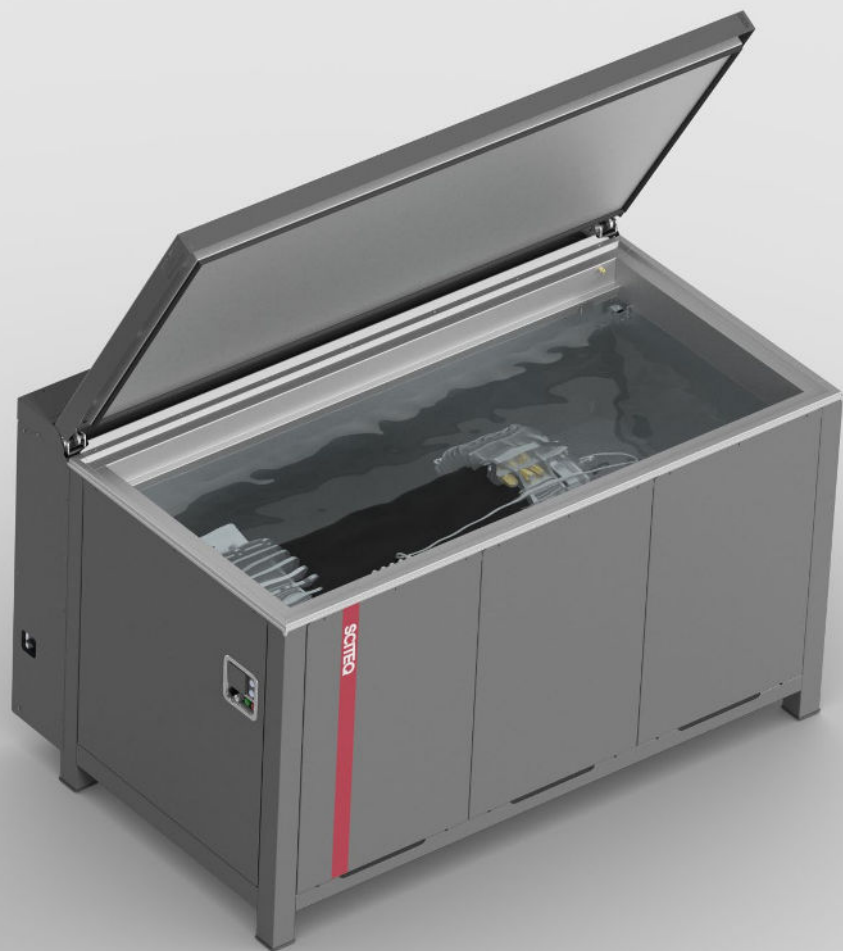

Technical specifications SIGMA Thermo Tank



	Standard models	
	1100x1100x1100	2400x1100x1100
Inner tank dimensions [mm]	1100x1100x1100	2400x1100x1100
Water mirror height WH [mm]	Approx: 1040	Approx: 1040
Loading height [mm]	1452	1452
Height with open lid [mm]	2838	2838
Volume [m3]	Approx: 1,25	Approx: 2,75
Weight, empty [kg]	Approx: 900	Approx: 1250
Weight with water [kg]	Approx: 2150	Approx: 4000
Material: piping and inner tank and lid*	AISI 304	AISI 304
Material: frame and coverplates	S235JR (Powder coated)	S235JR (Powder coated)
Power supply	3x 400 V, 50/60 HZ	3x 400 V, 50/60 HZ
Power consumption (Heating mode)	Approx: 5 KW, 7,3 A	Approx: 10 KW, 14,4 A
Approx: Heating time (6-95 °C)	12 Hours	26 Hours

*Other material available on request e.g. AISI 316.

Technical specifications SIGMA Thermo Tank



	Standard models	
	1100x1100x1100	2400x1100x1100
Ambient operation temperature	2 – 28 °C	2 – 28 °C
Temperature controller, built-in	Built-in	Built-in
Water temp. range at min. 22 °C ambient*	22 – 95 °C	22 – 95 °C
Additional Cooling availability (0-20 °C)**	√	√
Power consumption (Cooling mode)	Approx: 7 KW, 10,2 A	Approx: 7 KW, 10,2 A
Water supply	Normal tap 2-6 bar	Normal tap 2-6 bar
Max. recommended no. of inlets	40 pcs	125 pcs
Temperature control accuracy***	±0,5 °C	±0,5 °C
Temp. regulator resolution	0,1 °C	0,1 °C
SIGMA Software connection	√	√
Calibration certificate	√	√
CE Approval	√	√

*Chiller is required if temperature needed is below ambient. Chiller is for maintaining temperature, not for cooling down tank water. Chiller function is not available for ambient temperature above 40°C.

**Cooling requires additional chiller system, and maybe some changes in automation and piping also.

*** Accuracy is both for Chiller and heating mode.

About SIGMA modular pressure

SCITEQ

Features

SIGMA is the new generation of pressure testing helping our customers prepare for IoT and Industry 4.0.

The system consists of modular airless pressure modules designed to fit into an elegant standard cabinet with a compact footprint. The modularity enables easy configuration and extension of existing pressure cabinets, making SIGMA the most future proof and cost efficient solution in the market.

The web based SIGMA software is the latest development in pressure testing. The browser based interface allows for easy and intuitive operation. Quick-to-setup recipes as well as optimized real time monitoring & logging enabling comprehensive analysis option.



liteFIVE

The compact plug and play test unit with five fixed individual pressure stations ideal for smaller layouts. The valve system combined with SIGMA software ensure consistent and unparalleled pressure accuracy.

This cost effective and reliable solution is easy to setup and operate from any device via the web-based software.

The alarm visually alerts the user, in case of irregularities in the ongoing test.

Dimensions: B542xD740xH652 mm
Pressure range: 0-100 bar
Max. flow: 2 l/min.

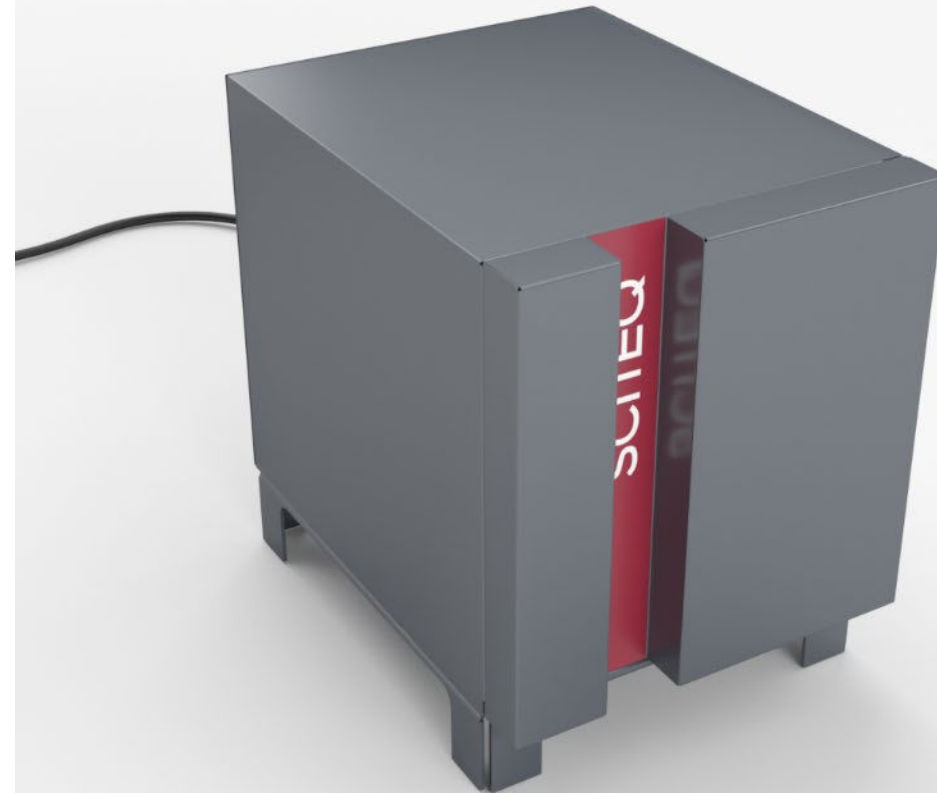

Advantages

SCITEQ's browser-based software is accessible from any device – any time, anywhere.

- ✓ One-page overview
- ✓ 4 different user levels
- ✓ Easy recipe set-up
- ✓ Thermo tanks assigned to pressure stations
- ✓ Dynamically adjusted real-time finish time
- ✓ Multiple simultaneous users
- ✓ Multiple specimen test per station
- ✓ SQL database compatible with all kind of servers
- ✓ OPC UA enabled





End closures without tie-bar

available in custom sizes, enabling you to test any pipe diameter. Made in certified stainless steel AISI 304. Also available as acid resistant AISI 316 when needed.



End closures with tie-bar

available in custom sizes, enabling you to test any pipe diameter. Made in certified stainless steel AISI 304. Also available as acid resistant AISI 316 when needed.

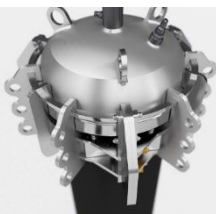

End closures large diameters

Patented design Air frame. For pressure testing of larger pipe diameters from 315 to 1600mm – and larger at request. in certified stainless steel AISI 304.



Hoses

SCITEQ is supplier of hoses to connect pressure stations to thermo tank or to samples. Supplied in different lengths according to need.



Stainless steel hoses

SCITEQ is supplying hoses for use inside the Tank. These are made with inner material suitable for the heat and pressure and protected with stainless outer hose.



Couplings

SIGMA equipment standard couplings are Tema 2510 quick connectors. Other systems can be supplied to fit customer needs.



Installation & training

SCITEQ's trained service technicians perform onsite installation of your new SCITEQ equipment as well as onsite or remote training of your operating personnel who will be using the equipment.



SCITEQ Care

You will find the level of service suitable for your test setup with SCITEQ Care. SCITEQ service engineers will visit you annually to perform the best service and calibration. With SCITEQ Basic, More or All Care package you gain access to a long list of advantages, discounts and free support from SCITEQ skilled technician. [Learn more about SCITEQ Care](#)

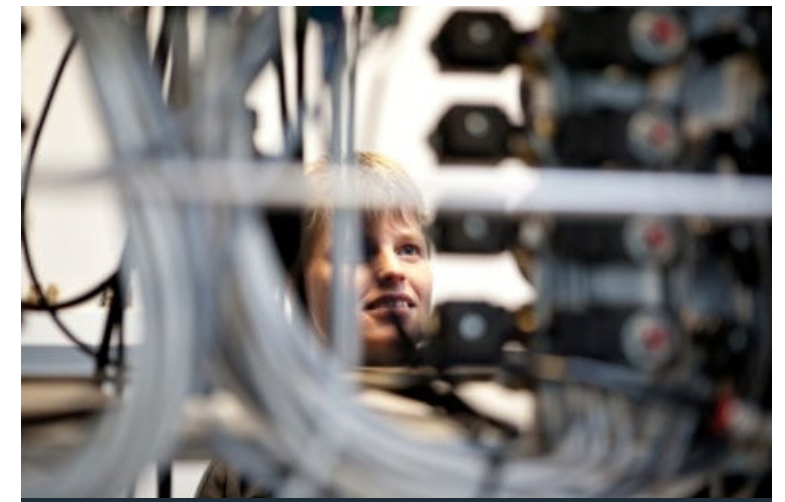

Support online & on-site

SCITEQ offers online and on-site support on all SCITEQ products, for fast and effective problem solving, training, setup, etc. If you have an unforeseen challenge or you need advise asap, you can contact service@sciteq.com or call us for urgent support.